

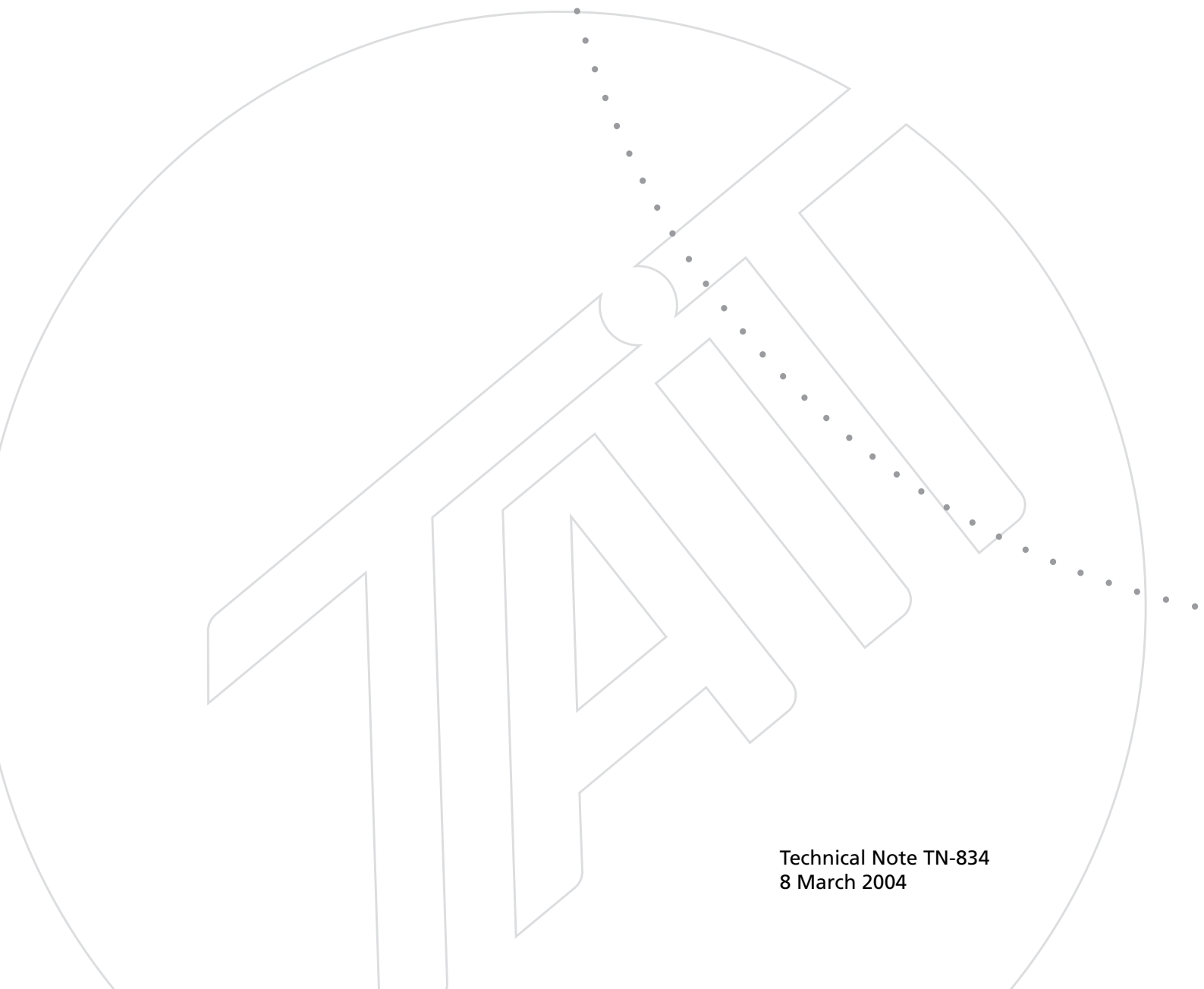

TB8100 base station

Hardware-
Switchable
Dual
Base Station



Technical Note TN-834
8 March 2004

This technical note provides information on the TB8100 hardware-switchable dual base station. It covers the following:

- Explains how two channels in a subrack are supported by hardware means
- Compares communications paths with those in a single channel subrack and a true, firmware-based dual channel subrack
- Describes the subrack layout and the control panel
- Describes how the hardware-switchable dual channel subrack operates
- Provides compatibility information
- Lists the limitations that this hardware solution imposes
- Gives instructions on how to upgrade to a hardware dual channel rack (factory only)

This technical note is intended for users, assemblers and technicians alike.

1 The Hardware-Switchable Solution

The TB8100 platform has been designed to support two channels in a subrack (and other configurations as well). The existing base station hardware design achieves this, but the firmware does not. If two reciters, two PAs, and a PMU are all interconnected on the standard control bus, communications fail because I²C and serial port messages are not arbitrated. This will be resolved in a later release of firmware.

In the meantime, a hardware-based solution has been developed to provide support for dual channel systems until the multi-base firmware release. This solution isolates the second channel's reciter and PA from the first channel's reciter, PA, and PMU. The main area affected is the subrack interconnect PCB and the control panel. The hardware dual channel solution uses solid state relays to isolate the two base station communication channels from each other. All other signals remain in parallel. Once multi-base software is operational, the same subrack PCB that interconnects all modules in parallel will be used.

When an order is placed for a dual base station, the hardware-switchable dual base station will be provided. After the multi-base release, a normal dual base station will be provided instead.

Single Channel Communication Paths

The diagram below illustrates the main communication paths in a single channel subrack. Note that the fans have power supplied from the relevant module with the rotation sensor alarm signal interfaced into the control panel. This signal is processed via the reciter.

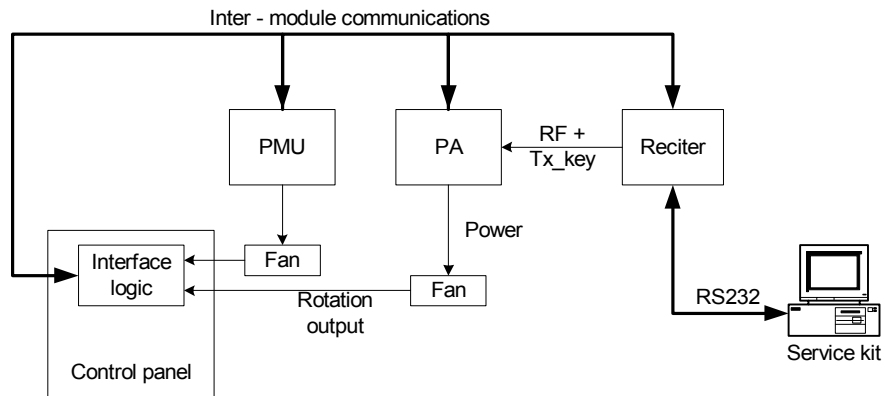

Hardware-Switchable Dual Base Station Communication Paths

The diagram below illustrates the main communication paths in a hardware dual channel subrack. Change-over switches and control logic mounted on a modified subrack interconnect PCB effectively allow two independent radio channels to fit within the same subrack. The switches are controlled by a keypress on the keypad of the control panel.

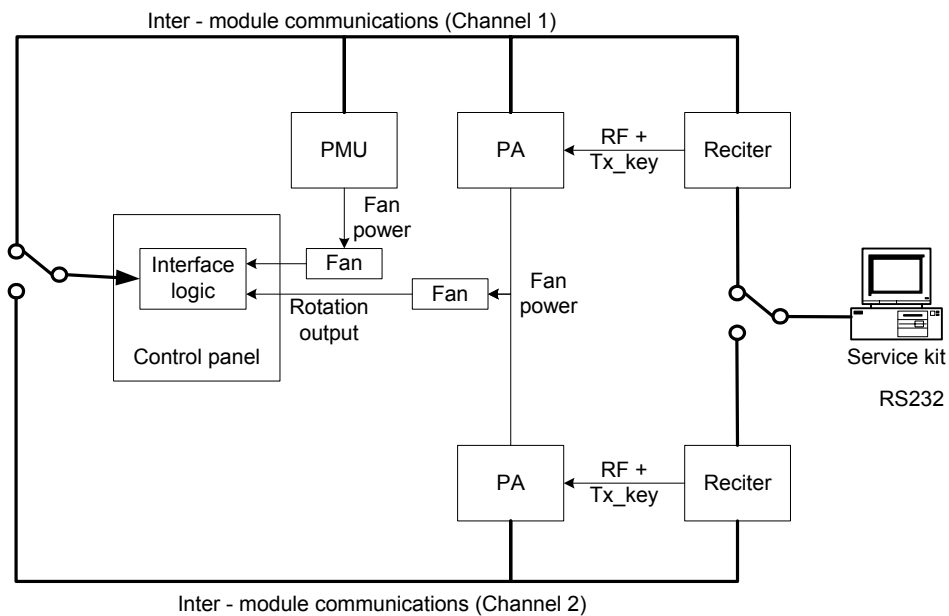

True Dual Base Station Communication Paths

The diagram below illustrates the main communication paths in a true dual base station. A similar structure also applies to other multi-reciter configurations. The reciters, PAs, and PMUs share common resources like the front panel serial port and inter-module communication bus. The 'multi-base' release will provide this software functionality. All signals are connected together in a parallel bus format via the subrack interconnect PCB.

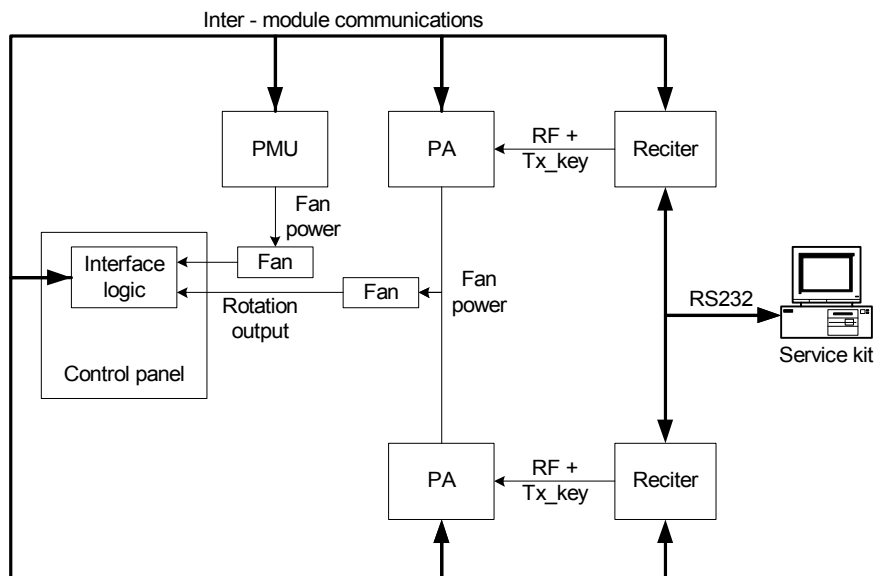

2 Subrack Layout

The module positions for dual channel base stations are shown below:

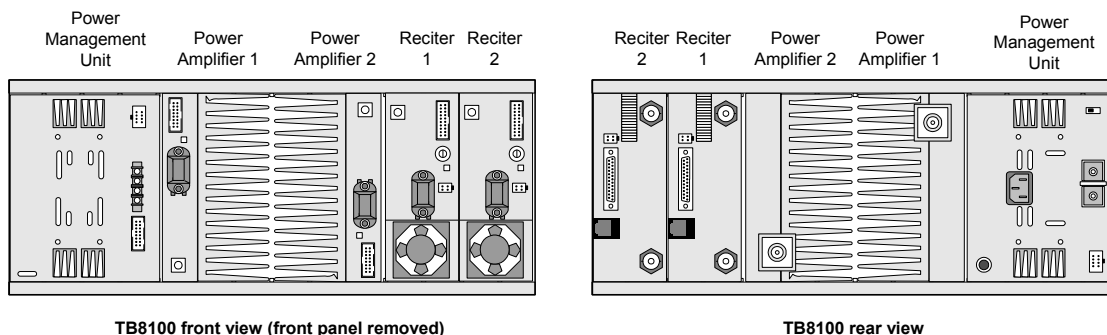

Note The locations of the channel 1 and channel 2 reciter and power amplifier are important. The cabling / subrack PCB system requires the modules to be installed in these locations.

3 Channel Selection at the Control Panel

The hardware-switchable solution uses a special control panel, the TBA2040.



On power-up, the control panel selects Channel 1. During normal operation, pressing 'I' selects Channel 1 and pressing 'II' selects Channel 2. Pressing a channel select button when that particular channel has already been selected has no effect.

4 Base Station Operation

The hardware-switchable solution changes base station functionality as follows.

Speaker

The operation of the speaker is defined by the settings stored in each reciter. This may be different to the currently displayed LED status.

Microphone and PTT

The microphone input feeds simultaneously to both Channel 1 and Channel 2. However, the PTT can only be used on the currently selected channel.

Control Panel LEDs

When you change channel, the control panel LEDs do not change. They continue to reflect the last changed status of the previous channel until you press a control panel button or the reciter issues an instruction to update an LED. If one LED needs to change, the status of all LEDs is updated.

To overcome this limitation, Tait recommends that you cycle through all three speaker modes immediately after changing channel, finally selecting the speaker mode you want. This forces the base station to refresh the control panel LED display.

RS-232

The RS-232 connection is only to the Reciter on the currently selected channel. You should disconnect the Service Kit before switching channels.

Fan Power and Sensors

The PA fan can be switched on by the PA on either channel. However, the fan rotation sensors report only to the currently selected channel. The other channel will conclude that the fan is not working and generate false alarms. We therefore recommend that you disable all fan failure alarms.

Protective diodes prevent the PA on a channel from being back-powered by the PA on the other channel via the fan power lines.

5 Recommended Configuration Settings

The following settings are recommended for hardware-switchable dual base station operation:

- Disable the fan alarm for the PA on Channels 1 and 2.
- Disable the fan alarm for the PMU on Channel 1.
- Disable Alarm Center/E-mail for Channels 1 and 2.
- Disable all PMU alarms for Channel 2.

6 Limitations

There are several limitations that the hardware dual channel solution imposes on the standard TB8100 platform. These are listed below:

Subrack

- The front panel LEDs, switches, and RS-232 interface are controlled by the currently selected channel.

- The second channel does not communicate to the PMU, but the PMU does provide power to it.
- E-mail alarm outputs are only possible from the currently selected channel.
- PA & PMU fan rotation detection should be turned off as this is not supported by the control bus which can be switched IN/OUT based on the currently selected channel.

Service Kit

- The Service Kit can only log on to the currently selected channel (1 or 2)
- Reciter Module details state ‘Reciter 1’ irrespective of the channel.
- Power Amplifier details state ‘Power Amplifier 1’ irrespective of the channel.
- As there is no PMU on Channel 2, no PMU settings for the channel will function. This includes the PMU battery voltage display, monitoring, diagnostics, and power management display.
- All PMU alarm LEDs on the Alarm screen of channel 2 will be grey.
- In the Configure > Base Station > Miscellaneous form for channel 2, the Power configuration areas will display voltages of zero and error messages will be displayed when you leave the form.
- All fan faults will not be detected / displayed / acted on (if disabled)
- The display of fan states in Diagnostic forms may be incorrect.
- If you read a configuration from Channel 2 then go to Configure > Alarms > Thresholds, the PMU battery voltages will be at zero. If you want to click OK to confirm any changes to the screen, you need to re-enter PMU voltages. If not, just click Cancel.

7 Compatibility Overview

It is essential that the correct combination of subrack interconnect PCBs and control panels are used, for example when replacing faulty control panels. The table below shows the compatible combinations.

	Single channel subrack	Dual channel subrack (future multi-base release)	Hardware dual channel subrack
Subrack interconnect PCB	XBAK22C0	XBAK22C0	XBAK22C1
Control panel	TBA2010 or TBA2020	TBA2010 or TBA2020	TBA2040

8 Upgrading to a hardware-switchable dual base station

(Factory only) To upgrade a subrack with equipment for two channels to a hardware dual channel subrack, you need to replace the rack interconnect PCB with a rack control PCB and modify the control panel.

Equipment to be used

To support the hardware-switchable dual channel functionality, the following assemblies should be used:

TBA2322-A000	Subrack Dual 5/50W
TBA2040	Control Panel hardware 2 Ch
XBAK2220	Dual 5/50W Wiring Kit
362-01123-00	Insular Dual HW Soln PCB
XBAK22C1	Rack Control PCB Dual Ch

Installing the Rack Control PCB

1. Remove the Rack Interconnect PCB and insulator from the rack. For details, see the Service Manual.
2. On the Rack Control Dual Channel PCB set the S1 switches as follows:

Switch	Function	State
1	CH1 Select Active	ON
2	CH2 Select Active	ON
3	Independent CH1 and CH2 channels	ON
4	Channel 2 I2C_CLK pullup	ON
5	Channel 2 I2C_DATA pullup	ON
6	Unused	OFF
7	Grounded CAN	OFF
8	Connected CH1 and CH2 channels	OFF

★ Turn Switch 8 off before turning Switch 3 on and vice versa.

3. Install the dual channel plastic insulator.

4. Install the Rack Control PCB Dual Channel.
5. Re-fit all retaining nuts.

Modifying the Control Panel

The Control Panel for a dual channel (TBA2020) has a PCB that must be modified to support the hardware-switchable solution. A control panel with a modified PCB becomes a TBA2040.

1. Remove the Control Panel from the rack (see the Installation and Operation Manual).
2. Remove the 6 Torx screws.
3. Detach the speaker connector.
4. Carefully remove the volume knob.
5. Carefully push the volume pot back through the front metal plate. There should be enough play in the keypad ribbon connector to expose the surface-mounted component side of the User Interface.
6. Connect an insulated wire from resistor R62 (see the PCB diagram) to pin 15 of J200 as shown by the black line.
7. Connect an insulated wire from resistor R64 to pin 5 of J200 as shown by the black line.
8. Remove resistor R73, indicated by the arrow.
9. Reassemble the Control Panel.

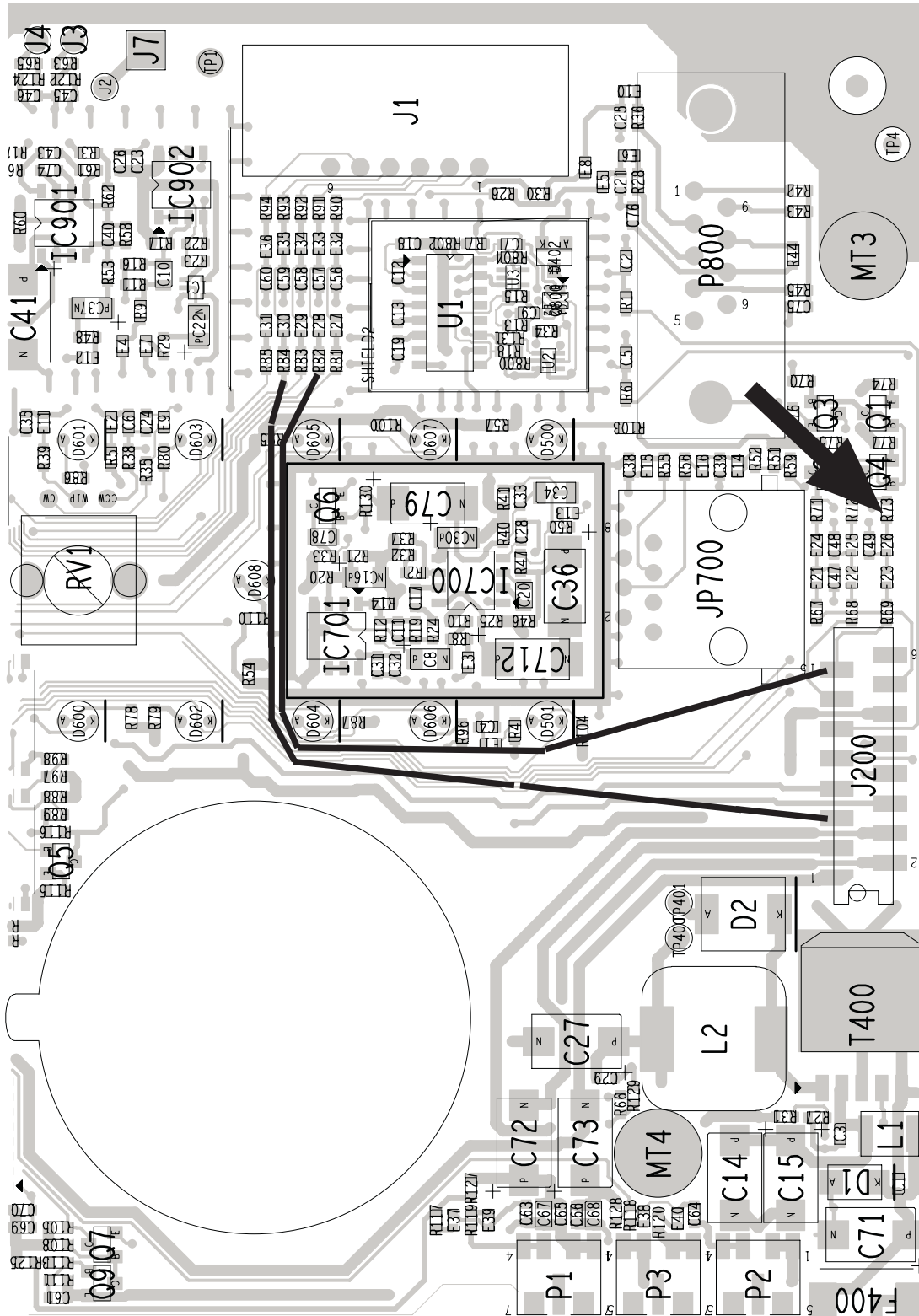

10 Issuing Authority

This TN was issued by: John Crossland
Technical Publications Manager

11 Publication History

Publication Date	Author
23 February 2004	B Williams/L Chisholm
8 March 2004	L Chisholm (minor updates)

12 Tait Contact Information

**Corporate Head Office
New Zealand** Tait Electronics Ltd, P.O. Box 1645, Christchurch, New Zealand
E-mail (Marketing): taitnet@taitworld.com
E-mail (Sales): sales@taitworld.com

Technical Support Technical Support Manager
Tait Electronics Ltd, P.O. Box 1645, Christchurch, New Zealand
E-mail: support@taitworld.com

Internet <http://www.taitworld.com>

